

GRIP-TWIST® DATA SHEET — Dimensions and Data [metric units]

TAPER THREADED GRIP-TWIST

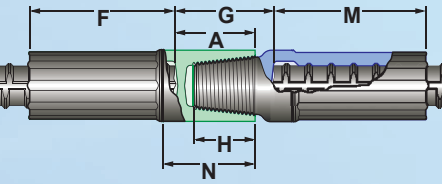

BPI® COUPLER SIZE	FEMALE COUPLER PRODUCT CODE	MALE COUPLER PRODUCT CODE	TAPER GRIP-TWIST COLOR CODE	COUPLER WEIGHT (kg)		DIMENSIONS (mm)					
				FEMALE	MALE	BAR INSERTION after swaging		REBAR GAP G	MALE INSERTION H	END ALLOWANCE A	Non-Swaged LENGTH N
						F	M				
3	TT3F	TT3M	Orange	0.09	0.08	35	35	38	14	25	29
4	TT4F	TT4M	Pink	0.14	0.14	45	45	45	19	30	33
5	TT5F	TT5M	Red	0.24	0.24	57	56	48	23	35	40
6	TT6F	TT6M	Yellow	0.45	0.41	70	67	54	29	40	46
7	TT7F	TT7M	Blue	0.68	0.64	79	78	64	33	48	54
8	TT8F	TT8M	Black	0.95	0.91	91	89	73	38	54	60
9	TT9F	TT9M	Red	1.29	1.29	102	99	83	45	62	70
10	TT10F	TT10M	Yellow	1.84	1.81	114	111	92	51	70	79
11	TT11F	TT11M	Blue	2.22	2.27	124	122	89	54	70	79
12	TT12F	TT12M	Brown	3.06	2.75	126	126	100	56	78	87
13	TT13F	TT13M	Black	3.67	3.56	135	135	105	60	83	92
14	TT14F	TT14M	Pink	4.11	4.13	154	149	111	64	84	98
16	TT16F	TT16M	Gray	6.80	6.67	170	170	136	73	105	121
18	TT18F	TT18M	Red	9.21	9.62	200	194	143	83	110	129

TRANSITION GRIP-TWIST

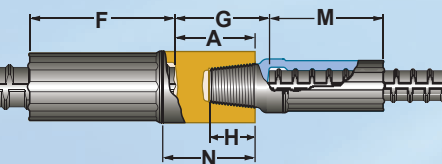

COUPLER SIZE US [metric]	COUPLER OUTSIDE DIAMETER (mm)
#3 [10mm]	19
#4 [12mm]	22
#5 [16mm]	28
#6 [20mm]	35
#7 [22mm]	39
#8 [25mm]	44
#9 [29mm]	48
#10 [32mm]	55
#11 [36mm]	60
#12 [38mm]	68
#13 [40mm]	70
#14 [43mm]	73
#16 [50mm]	86
#18 [57mm]	96

BPI® COUPLER SIZE	FEMALE TRANSITION PRODUCT CODE	MALE COUPLER PRODUCT CODE	COLOR CODE		COUPLER WEIGHT (kg)		DIMENSIONS (mm)						
			TAPER FEMALE TRANS.	TAPER MALE	FEMALE	MALE	BAR INSERTION after swaging		REBAR GAP G	MALE INSERTION H	END ALLOWANCE A	Non-Swaged LENGTH N	
							F	M					
4/3	TT4/3F	TT3M	Pink	Orange	0.16	0.08	45	35	41	14	30	33	
5/4	TT5/4F	TT4M	Red	Pink	0.29	0.14	57	45	48	19	35	40	
6/4	TT6/4F	TT4M	Yellow	Pink	0.51	0.14	70	45	54	19	40	46	
6/5	TT6/5F	TT5M		Red	Red	0.48		0.24	56	54			23
7/5	TT7/5F	TT5M	Blue	Red	0.75	0.24	79	56	60	23	48	54	
7/6	TT7/6F	TT6M		Yellow	Yellow	0.71		0.41	67	64			29
8/5	TT8/5F	TT5M	Black	Red	1.14	0.24	91	56	67	23	54	60	
8/6	TT8/6F	TT6M		Yellow	Yellow	1.10		0.41	67	70			29
8/7	TT8/7F	TT7M		Blue	Blue	1.03		0.64	78	73			33
9/5	TT9/5F	TT5M	Red	Red	1.60	0.24	102	56	76	23	62	70	
9/6	TT9/6F	TT6M		Yellow	Yellow	1.56		0.41	67	76			29
9/7	TT9/7F	TT7M		Blue	Blue	1.49		0.64	78	79			33
9/8	TT9/8F	TT8M		Black	Black	1.41		0.91	89	83			38
10/6	TT10/6F	TT6M	Yellow	Yellow	2.22	0.41	114	67	86	29	70	79	
10/7	TT10/7F	TT7M		Blue	Blue	2.16		0.64	78	86			33
10/8	TT10/8F	TT8M		Black	Black	2.07		0.91	89	89			38
10/9	TT10/9F	TT9M		Red	Red	1.95		1.29	99	92			45
11/7	TT11/7F	TT7M		Blue	Blue	2.74		0.41	124	78			86
11/8	TT11/8F	TT8M	Black	Black	2.65	0.91	89	89		38			
11/9	TT11/9F	TT9M	Red	Red	2.53	1.29	99	92		45			
11/10	TT11/10F	TT10M	Yellow	Yellow	2.38	1.81	111	95	50				
14/7	TT14/7F	TT7M	Pink	Blue	3.96	0.41	108	78	89	33	72	83	
14/8	TT14/8F	TT8M		Black	Black	3.88		0.91	89	92			38
14/9	TT14/9F	TT9M		Red	Red	3.75		1.29	99	92			45
14/10	TT14/10F	TT10M		Yellow	Yellow	3.60		1.81	111	95			50
14/11	TT14/11F	TT11M	Blue	Blue	3.43	2.27	125	92	54				
18/9	TT18/9F	TT9M	Red	Red	8.26	1.29	127	99	108	45	86	102	
18/10	TT18/10F	TT10M		Yellow	Yellow	8.12		1.81	111	108			5
18/11	TT18/11F	TT11M		Blue	Blue	7.94		2.27	125	105			54
18/14	TT18/14F	TT14M	Pink	Pink	7.44	4.13	149	114	64				

GRIP-TWIST POSITION COUPLER

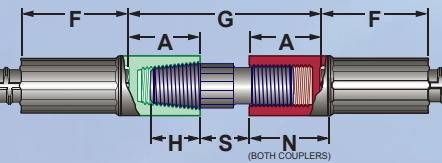

BPI® COUPLER SIZE	FEMALE POSITION PRODUCT CODE	STUD PRODUCT CODE	POSITION TAPER GRIP-TWIST COLOR CODE	COUPLER WEIGHT (kg)		DIMENSIONS (mm)					
				Taper FEMALE	POSITION w/ Stud	BAR INSERTION after swaging F	REBAR GAP G	TAPER MALE INSERTION H	END ALLOWANCE A	Non-Swaged LENGTH N	SPACE after assembly S
5	5PF	TT5RP	Red	0.24	0.41	57	98	24	35	40	29
6	6PF	TT6RP	Yellow	0.45	0.73	70	111	29	40	46	32
7	7PF	TT7RP	Blue	0.68	1.16	79	137	33	48	54	41
8	8PF	TT8RP	Black	0.95	1.56	91	146	38	54	60	38
9	9PF	TT9RP	Red	1.29	2.20	102	165	45	62	70	41
10	10PF	TT10RP	Yellow	1.84	3.15	114	187	51	70	79	48
11	11PF	TT11RP	Blue	2.22	3.99	124	184	54	70	79	45
12	12PF	TT12RP	Brown	3.06	5.01	126	204	56	78	87	48
13	13PF	TT13RP	Black	3.67	5.97	135	217	60	83	92	51
14	14PF	TT14RP	Pink	4.11	6.94	154	222	64	84	98	54
16	16PF	TT16RP	Gray	6.80	11.30	170	264	73	105	121	54
18	18PF	TT18RP	Red	9.21	15.56	200	273	83	110	129	54

GRIP-TWIST FLANGED COUPLER

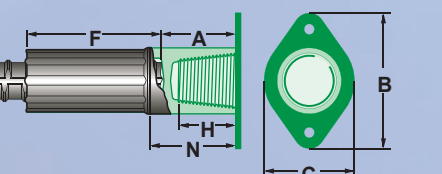

BPI® COUPLER SIZE	FEMALE FLANGED PRODUCT CODE	TAPER GRIP-TWIST COLOR CODE	FEMALE COUPLER PLUS FLANGE WEIGHT (kg)	DIMENSIONS (mm)					
				BAR INSERTION after swaging F	FLANGE HEIGHT B	FLANGE WIDTH C	MALE INSERTION H	END ALLOWANCE A	Non-Swaged LENGTH N
4	TT4FWFL	Pink	0.15	45	49	35	19	30	33
5	TT5FWFL	Red	0.26	57	60	41	24	35	40
6	TT6FWFL	Yellow	0.48	70	70	48	29	40	46
7	TT7FWFL	Blue	0.71	79	75	52	33	48	54
8	TT8FWFL	Black	0.98	91	83	57	38	54	60
9	TT9FWFL	Red	1.32	102	87	60	45	62	70
10	TT10FWFL	Yellow	1.88	114	97	67	51	70	79
11	TT11FWFL	Blue	2.27	124	95	70	54	70	79

GRIP-TWIST® Mechanical Anchorage — Dimensions and Data [metric units]

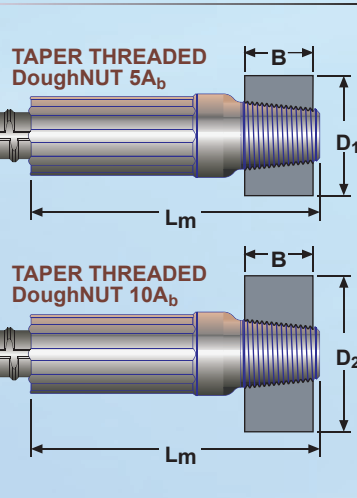

Coupler Size US [metric]	Male Coupler Product Code	TDS Head Product Code	TDX Head Product Code	Male Swaged Length Lm (mm)	Thickness B (mm)	Head Diameter and Weight *		Head Diameter and Weight **	
						TDS Series [5A _b]	TDX Series [10A _b]	D1 (mm)	Wt (kg)
#4 [12mm]	TT4M	4TDS	4TDX	75	19	32	0.10	45	0.21
#5 [16mm]	TT5M	5TDS	5TDX	92	22	38	0.16	51	0.32
#6 [20mm]	TT6M	6TDS	6TDX	110	24	45	0.23	60	0.48
#7 [22mm]	TT7M	7TDS	7TDX	127	32	51	0.39	73	0.93
#8 [25mm]	TT8M	8TDS	8TDX	145	33	60	0.59	83	1.25
#9 [29mm]	TT9M	9TDS	9TDX	165	38	70	0.86	95	1.86
#10 [32mm]	TT10M	10TDS	10TDX	184	41	73	1.00	102	2.25
#11 [36mm]	TT11M	11TDS	11TDX	194	45	83	1.50	114	3.08
#12 [38mm]	TT12M	12TDS	12TDX	204	48	86	1.61	121	3.58
#13 [40mm]	TT13M	13TDS	13TDX	218	51	89	1.73	127	4.30
#14 [43mm]	TT14M	14TDS	14TDX	238	54	95	2.18	140	5.62
#16 [50mm]	TT16M	16TDS	16TDX	275	62	114	3.65	159	8.28
#18 [57mm]	TT18M	18TDS	18TDX	310	70	127	4.94	184	12.6

* Head Cross Sectional Area is approximately 5 x Rebar Area

** Head Cross Sectional Area is approximately 10 x Rebar Area

GRIP-TWIST STRUCTURAL CONNECTOR

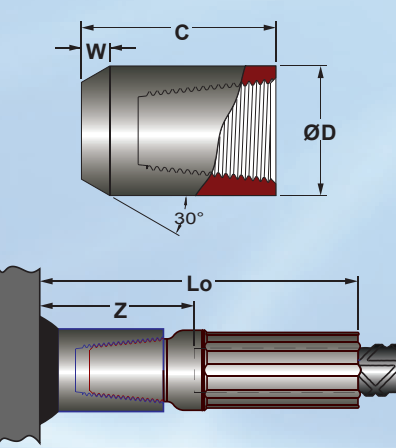

Structural Connector Size US [metric]	Structural Connector Product Code	Taper Grip-Twist Color Code	Structural Connector Weight (kg)	DIMENSIONS (mm)				
				Structural Connector Outside Dia. D	Structural Connector Length C	Weld Bevel Length W	Gap Z	Overall Length Lo
#4 [12mm]	TT4SC	Pink	0.07	22	35	5	44	89
#5 [16mm]	TT5SC	Red	0.14	29	43	6	54	110
#6 [20mm]	TT6SC	Yellow	0.27	35	51	6	64	130
#7 [22mm]	TT7SC	Blue	0.39	40	59	8	75	152
#8 [25mm]	TT8SC	Black	0.52	45	67	10	84	173
#9 [29mm]	TT9SC	Red	0.73	49	76	11	97	197
#10 [32mm]	TT10SC	Yellow	1.00	56	86	13	106	218
#11 [36mm]	TT11SC	Blue	1.25	60	91	14	114	238
#12 [38mm]	TT12SC	Brown	1.30	68	96	15	118	244
#13 [40mm]	TT13SC	Black	1.80	70	104	16	126	261
#14 [43mm]	TT14SC	Pink	2.29	73	111	17	137	286
#16 [50mm]	TT16SC	Gray	3.50	86	131	19	162	332
#18 [57mm]	TT18SC	Red	5.33	97	146	22	179	373

GRIP-TWIST® — Equipment and Installation

A Bench Press BP2600 fitted with a two-piece die set and powered by an electrically-driven hydraulic pump is used by the rebar fabricator to efficiently swage Grip-Twist® coupler components. The equipment operator depresses a foot control to actuate the system. As the ram extends and pushes the dies towards each other, the coupler component is forced to deform around the rebar and interlock with the bar profile. When a swaging bite has been completed, a pressure switch automatically stops the process and the operator retracts the ram for the next bite. For ease of use, swaging dies are color coded and stamped with a serial number that indicates the rebar and coupler size. Color codes are shown on Grip-Twist® Dimensions and Data Charts. *NOTE: In lieu of shop installation, it may sometimes be appropriate to use BPI-Grip field-swaging equipment such as press models BG1140M or BG750M - contact BPI for assistance with your application.*

BP2600

Bench press for swaging all sizes up to Ø 57mm. Double acting cylinder produces 300 tons of force connected to 10 or 15 hp pump for high fabrication shop productivity - includes foot control, lifting eyes and leveling feet - weighs 725 kg.

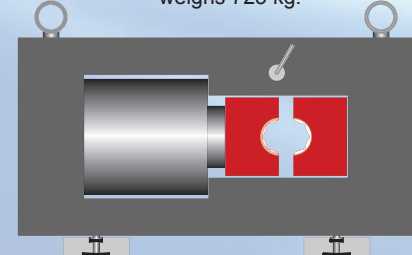

BPI®
Equipment is available for lease or purchase. Equipment must be used in accordance with manuals, lease agreements, manufacturers' directions and all safety instructions.

BPI® COUPLER SIZES Ø10 - Ø57 mm

While the information contained in this document is believed to be accurate at the time of publication, BPI reserves the right to make changes, design modifications, corrections and other revisions as it sees fit, without notice. All products described herein are supplied in accordance with BPI's standard Terms and Conditions of Sale. This document is of a promotional nature only. Aspects of structural design, evaluation of product fitness for use, suitability or similar attributes are the responsibility of others.



BarSplice Products, Inc., 4900 Webster Street, Dayton OH 45414, USA
 •Tel: (937) 275-8700 •Fax: (937) 275-9566 •E-mail: bar@barsplice.com

Copyright © 2012, Barsplice Products, Inc., "BPI". All rights reserved.



REV.H2 11/20/2012